

System Identification of Discrete Model for photovoltaic greenhouse

Charaabi Foued¹, Mechergui Hfaied², Haddouk Amira³

Department of Electrical Engineering
Ecole Nationale Supérieure d'Ingénieurs de Tunis
University of Tunis, Tunisia
¹charaabi.foued@gmail.com,
²Hfaiedh.Mechergui@esstt.rnu.tn,
³haddoukamira@yahoo.com

Abstract— This paper deals with the problem of modeling and control of greenhouses inside climate defined by two variables: the temperature and humidity. The control objective aims to ensure a favorable inside microclimate for the culture development and to minimize the production cost. Achieving this objective is difficult, due to the complexity of the phenomena involved in the plant growth process: the two variables are correlated and very sensitive to the outside weather and also to many other practical constraints (actuators, moistening cycle ...).

Keywords— component; greenhouse model; temperature; humidity; control ; pad and fan system.

I. INTRODUCTION

The main objective of greenhouse crop production is to increment the economic benefits of the farmer compared to traditional agriculture methods. The implementation of an adequate automatic control system for controlling the climate of the greenhouse (temperature, humidity) can lead to an increased production and quality of the horticultural products, reducing pollution and energy consumption.

In recent years, there have been many researches on analysis and control of the environment inside greenhouses. To do this control efficiently, it is necessary to elaborate models that adequately describe the system to be controlled. Generally, there are three categories of models that could be used to simulate and predict the greenhouse environment.

The first category is based on the concept of energy and mass balance. The drawback of this methodology is that these models are difficult to tune in practice, since they use a large number of parameters and physical variables which are time-variant and weather-dependent.

The second category is based on soft computing and computational intelligence such as artificial neural networks and fuzzy clustering. These techniques are applicable when

The expert knowledge is not available and only input-output data of the system is available.[1]

II. THE PROPOSED GREENHOUSE

The proposed greenhouse in this work consists mainly of eight components as shown in Figure 1. These components are polyethylene white coating, water impermeable plastic material cover, woven water-porous shade curtain material, aluminum pad, cool air fan, sumps, pump and soil. In this work, the proposed cooling system consists mainly, of four components. These components are aluminum pad, cool air fan, pump and sump. This cooling system can maintain a greenhouse interior temperature and relative humidity to about 20°C and 70% respectively. [7-8]

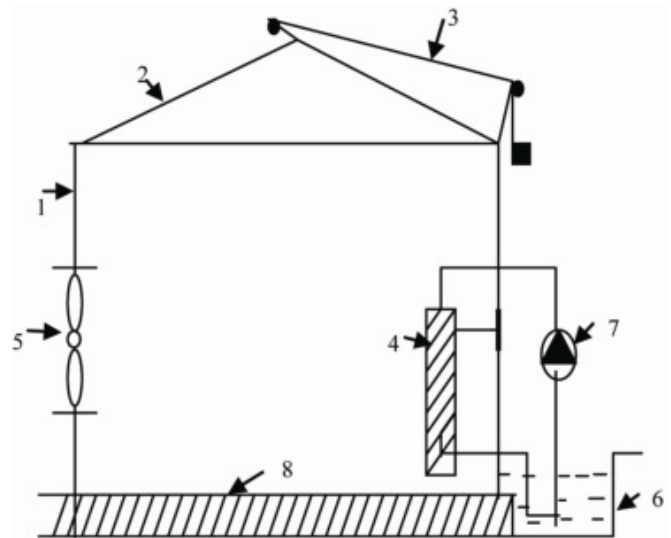

Fig. 1. Proposed greenhouse(**)

III. COOLING SYSTEM MATHEMATICAL MODELING

A. PAD-FAN SUBSYSTEM MATHEMATICAL MODELING

1) Fan Mathematical Modeling

(**) 1 Polyethylene white coating reflects 50% of radiation; 2. Water impermeable plastic material cover; 3. Greenhouse shading (woven water-porous shade curtain material); 4. Aluminum pad; 5. Cool air fan; 6. Sumps; 7. Pump; 8. Soil

Pad-fan systems are commonly used for cooling the environment inside greenhouses to be suitable for growing plants (e.g., nurseries, residential and commercial vegetables or flower production, etc). Fans push outside air toward a wet pad, bringing cooled and humidified air into the greenhouse. Typically, the wet pads and fans are located on opposite walls so that the evaporative cooled air is pulled from one end of the structure to the other. A linear model of a simple fan consists of a mechanical equation and electrical equation as determined in the following:

$$V_a = E + I_a R_a + L_a \frac{dI_a}{dt} \quad (1)$$

$$T_e = T_l + B_m \omega_M + J \frac{d\omega_m}{dt} \quad (2)$$

$$P_{fan} = N^2 D^2 \nu \quad (3)$$

Where N is fan speed, D is fan diameter, ν is specific weight of air (11.82 N/m²), R_a is armature resistance (Ω), L_a is armature inductance (H), V_a is terminal voltage (V), J is moment of inertia (kg·m²), B is damping factor of mechanical system (N·m·s), I_a is armature current (A), T_L is load torque (N·m), T_e is developed torque, and ω is speed of rotation.

2) Pad Mathematical Modeling

The cooling efficiency η_c of the evaporative pad cooling system is defined by [10- 11]

$$\eta_c = \frac{T_{db,0} - T}{T_{db,0} - T_{wb,0}} \quad (4)$$

Where $T_{db,0}$ and $T_{wb,0}$ are the dry and wet bulb temperatures of the air outside the greenhouse in °C, and T is the dry bulb temperature of the cooled air passing over the wet pad in °C. Equation (4) works well for evaporative pad cooling systems because the cooling process (an adiabatic process) occurs nearly at a constant wet bulb temperature of the outside air. Equation (4) can be rearranged as :

$$T = T_{db,0} - \eta_c (T_{db,0} - T_{wb,0}) = (1 - \eta_c) T_{db,0} + \eta_c T_{wb,0}$$

$$\Delta T = \eta_c (T_{db,0} - T_{wb,0}) = (T_{db,0} - T) \quad (5)$$

By assuming a value of 80% for the efficiency of evaporative pad cooling systems Equation (5) can be written as:

$$T = 0.2T_{db,0} - 0.8T_{wb,0} \quad (6)$$

- Energetic and water balance[4]

$$T_a(k+1) = \frac{t_s}{C_{cap,q}} (E_h + E_s - E_v - E_C) + T_a(k) \quad (7)$$

Where:

$E_c = h_T(T_a - T_0)$: the amount of heat lost by conduction and convection from the walls

$E_P = C_{cap,q,v} V(T_a - T_0)$: the energy lost by the Pad-Fun system

$E_s = \tau S_0$: the quantity of energy received by the solar rays

E_h : energy supply by heating system

$$w_a(k+1) = t_s(w_p - w_h) + w_a(k) \quad (8)$$

Where :

$w_p = \frac{\nu}{C_{cap,h}}(w_a - w_0)$: Humidity received from the Pad-Fun system

$w_h = \frac{h_w}{C_{cap,h}}(w_a - w_0)$: Humidity lost by the convection and conduction.(heating system)

The relative humidity and the temperature are two widely used indicators of the amount of moisture in air and are too complex to be done easily without the help of a calculator or computer [2].

So we need to use advanced modeling techniques and identification processes for the modeling of (AR - ARX - ARMAX - ARIMAX).

IV. GREENHOUSE ARX IDENTIFICATION MODEL

A. ARX STRUCTURE

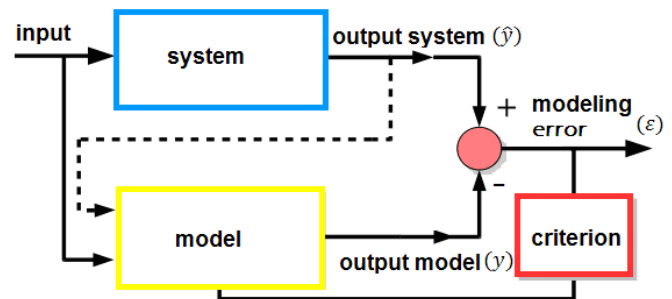

Fig. 2. ARX General Structure

This technique consists in determining an initial model of our real system and compares the system output and the model output.

B. GREENHOUSE MIMO STRUCTURE

Agricultural greenhouse model is considered as being a MIMO system with two input and two outputs.

The inputs are the ventilation supply voltage (pad and fan system) and the second is the ventilation supply (moisture fan system). Outputs are the temperature and relative humidity.

The following figure presents the system structure with all relationships between inputs-outputs

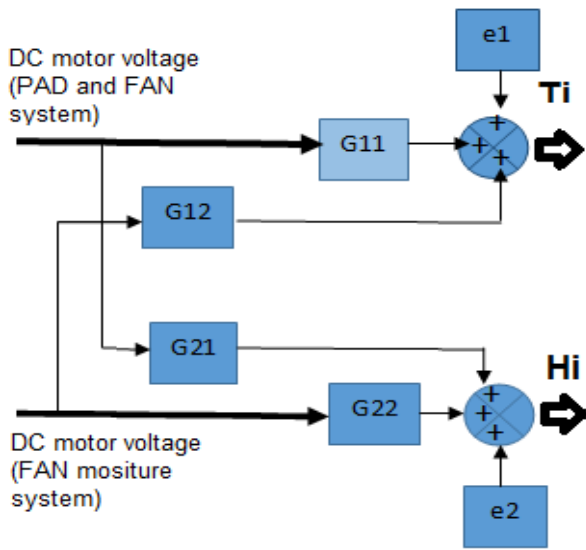

Fig. 3. Greenhouse MIMO system

$$\begin{bmatrix} T_{in}(k) \\ H_{in}(k) \end{bmatrix} = \begin{bmatrix} G_{11}(z) & G_{12}(z) \\ G_{21}(z) & G_{22}(z) \end{bmatrix} \begin{bmatrix} U_1(k) \\ U_2(k) \end{bmatrix} + \begin{bmatrix} C_1(z) & 0 \\ 0 & C_2(z) \end{bmatrix} \begin{bmatrix} e_1(k) \\ e_2(k) \end{bmatrix} \quad (9)$$

T_{in} : temperature inside the greenhouse

H_{in} : relative humidity inside the greenhouse

U_1 : signal command of the ventilator speed (pad-fan system)

U_2 : signal command of the heating system

e_1, e_2 : are considered like a perturbations

$G_{ii}(z)$ are the transfer functions

$$[G(z^{-1})] = \begin{bmatrix} G_{11}(z^{-1}) & G_{12}(z^{-1}) \\ G_{21}(z^{-1}) & G_{22}(z^{-1}) \end{bmatrix} \quad (10)$$

C. EXPERIMENTAL PROTOOL

Proper identification requires the use of an excitation signal (command) of the process, high frequencies. This signal will be superimposed on the static value of the order corresponding to the operating point about which it is desired to make the identification process. In general, we use a S.B.P.A. (because rich frequency). In order to identify the static gain, it takes at least one of the pulses of the SBPA greater than the rise time of the system to be identified. The amplitude of the S.B.P.A. should not exceed a few% of the static control signal. The acquisition is most often using a computer equipped with a card IO acquisition (including ADC and DAC circuits) [3].

We choose the ARDUINO card because it's not expensive and very easy to communicate with Matlab-Simulink.

We place three sensors pairs of humidity and temperature in different positions in order to scan the entire surface of the greenhouse. The figure 4 represents simulation on MATLAB.

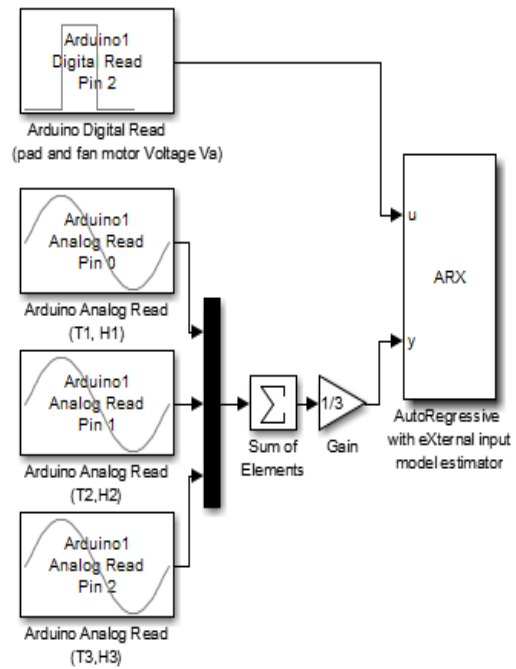

Fig. 4. Matlab-simulink to Arduino board

D. IDENTIFICATIONS AND VALIDATION OF THE DIFFERENT TRANSFER FUNCTIONS

To determinate $G_{11}(z^{-1})$ and $G_{21}(z^{-1})$ you should put $U_1 = 1$ and $U_2 = 0$

To determinate $G_{12}(z^{-1})$ and $G_{22}(z^{-1})$ you should put $U_1 = 0$ and $U_2 = 1$

❖ $G_{11}(z^{-1})$ and $G_{21}(z^{-1})$

In this case we reset the input $U_2 = 0$ and we measure **T** and **H** outputs.

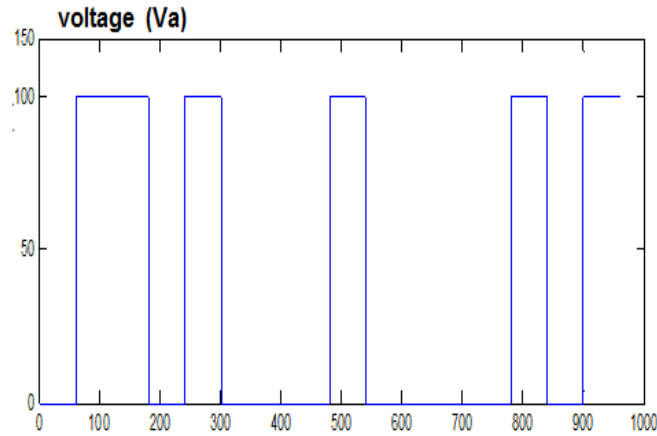

Fig. 5. Evolution of U_1 [8]

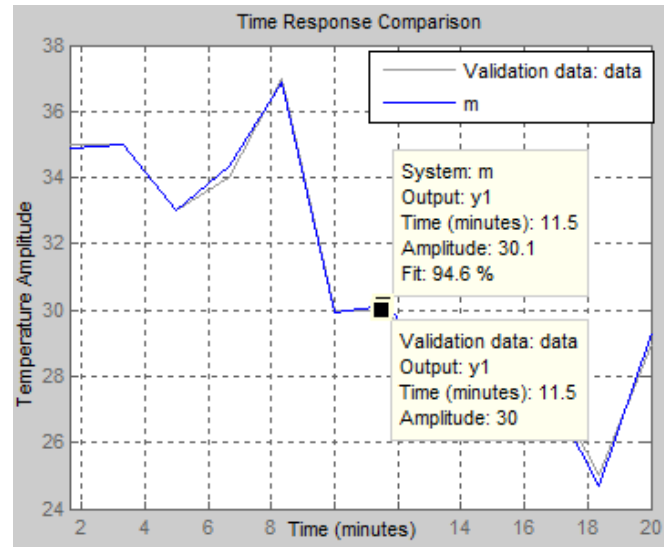

Fig. 6. Validation of $G_{11}(z)$

Using the matlab tool, the ARX modeling of a system and achieved through the following functions:

```
data = iddata (Tin 'U_1,60);
m = arx (data, [4 2 1]);
compare (data, m);
```

We note that the error is very small and therefore we must consider the following transfer function

$$G_{11}(z^{-1}) = \frac{B(z^{-1})}{A(z^{-1})} = \frac{0.029z^{-1} + 0.004z^{-2}}{1 - 0.607z^{-1} - 0.326z^{-2}} \quad (10)$$

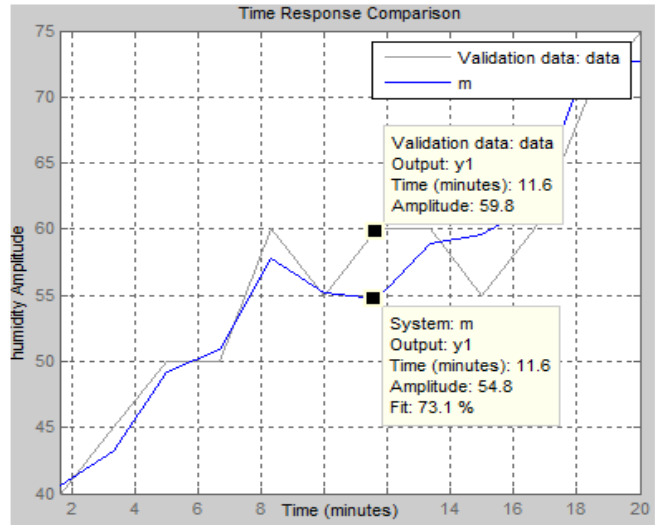

Fig. 7. Validation of $G_{21}(z)$

$$G_{21}(z^{-1}) = \frac{B(z^{-1})}{A(z^{-1})} = \frac{0.00027z^{-1} - 0.03347z^{-2}}{1 - 0.889z^{-1} + 1.5z^{-2} - 1.611z^{-3}} \quad (11)$$

❖ $G_{12}(z^{-1})$ and $G_{22}(z^{-1})$

In this case we reset the input $U_1 = 0$ and we measure **T** and **H** outputs

$$G_{22}(z^{-1}) = \frac{B(z^{-1})}{A(z^{-1})} = \frac{-0.004z^{-1} - 0.023z^{-2}}{1 - 0.606z^{-1} - 0.63z^{-2} + 0.198z^{-3}} \quad (12)$$

$$G_{12}(z^{-1}) = \frac{B(z^{-1})}{A(z^{-1})} = \frac{-0.0031z^{-1} + 0.009z^{-2}}{1 - 0.583z^{-1} - 0.335z^{-2}} \quad (13)$$

It is clear that the identification algorithm gave a satisfactory result as the estimated error does not exceed 5% in absolute value. Confirmer for the model validity is a function that

calculates the percentage change defined between two signals which use the variance formulas.

$$VAR = \max \left\{ 1 - \frac{\text{var}(y - \bar{y})}{\text{var}(y)}, 0 \right\} 100\% \quad (14)$$

TABLE I

Validation	G_{11}	G_{21}	G_{22}	G_{12}
$VAR = \max \left\{ 1 - \frac{\text{var}(y - \bar{y})}{\text{var}(y)}, 0 \right\} 100\%$	94%	73%	91%	90%

V. CONCLUSION

This theoretical and experimental study has shown that the principle can be applied to the identification of a greenhouse grown ARX model, drawing on the research and identification methodology. Thus, a complex model describing realistically strong complement between temperature and internal humidity of the greenhouse.

The obtained model is represented by a transfer matrix (2,2) which recognizes the different interactions of entries that are the average value of the power of the pad and fan system voltage magnitudes and quantities outputs of which are the temperature and relative humidity.

The performance of the proposed technique is demonstrated on the air temperature and humidity inside greenhouse modeling. The obtained results are satisfactory and we think to insert the elaborated model in an adaptive control scheme to ensure an increased production and quality of the horticultural

products and reducing pollution and energy consumption. This will be the object of our forthcoming work.

REFERENCES

- [1] Alduchov, O. A., and R. E. Eskridge, 1996: Improved Magnus form approximation of saturation vapor pressure. *J. Appl. Meteor.*, 35, 601–609
- [2] Bolton, D., 1980: The computation of equivalent potential temperature. *Mon. Wea. Rev.*, 108, 1046–1053.
- [3] J. Damagnez and J.P Chipale, `Recent developments in Research on the Microclimate of Greenhouses: Applications to Plastic Greenhouses, INRA, Enc to T528
- [4] B.Nielsen and H.Madsent, Identification of Transfert Function for Control of Greenhouse Air Temperature, *J. Agric.Engng. Res*1995.
- [5] N. Bibi-Triki, F Benyarou, B. Benyoucef et M.A.R. El-Sayed., Bilan thermique d'estimation des besoins énergétiques de la serre agricole tunnel à double paroi constituée dans sa face Nord d'un mur en panneau sandwich. *Rev. Energ Ren : Valorisation* ISSN 1112-2242 (1999) 77-82
- [6] N. Bibi-Triki1, S. Bendimerad1, A. Chermiti1, T Mahdjoub1, B.Draoui2, A. Abène " Modeling, Characterization and Analysis of the dynamic behavior of heat transfers through polyethylene and glass walls of Greenhouses" seventh international conference of Materials sciences(CSM7),Beirut-lebanon,20-22May 2010
- [7] K. S. Kumar, K. N. Tiwari and M. K. Jha, "Design and Technology for Greenhouse Cooling in tropical and Sub-tropical Regions: A Review," *Energy and Buildings*, Vol. 41, 2009, pp. 1269-1275.
- [8] C. Kittas, M. Karamanis and N. Katsoulas, "Air Temperature Regime in a Forced Ventilated Greenhouse with Rose Crop," *Energy and Buildings*, Vol. 37, 2005, pp. 807-812.
- [9] R. A. Bucklin, J. D. Leary, D. B. McConnell and E. G. Wilkerson, "Fan and Pad Greenhouse Evaporative Cooling Systems," University of Florida, Florida, 2010.
- [10] Abdel-Ghany and A. M. Kozai, "Dynamic Modeling of the Environment in a Naturally Ventilated, Fog-Cooled Greenhouse," *Renewable Energy*, Vol. 31, No. 10, 2006, pp. 1521-1539.
- [11] A. Ganguly and S. Ghosh, "Modeling and Analysis of a Fan-Pad Ventilated Floricultural Greenhouse," *Energy and Buildings*, Vol. 39, No.10, 2007, pp. 1092-1097